

Detail A
Maßstab: 1:2

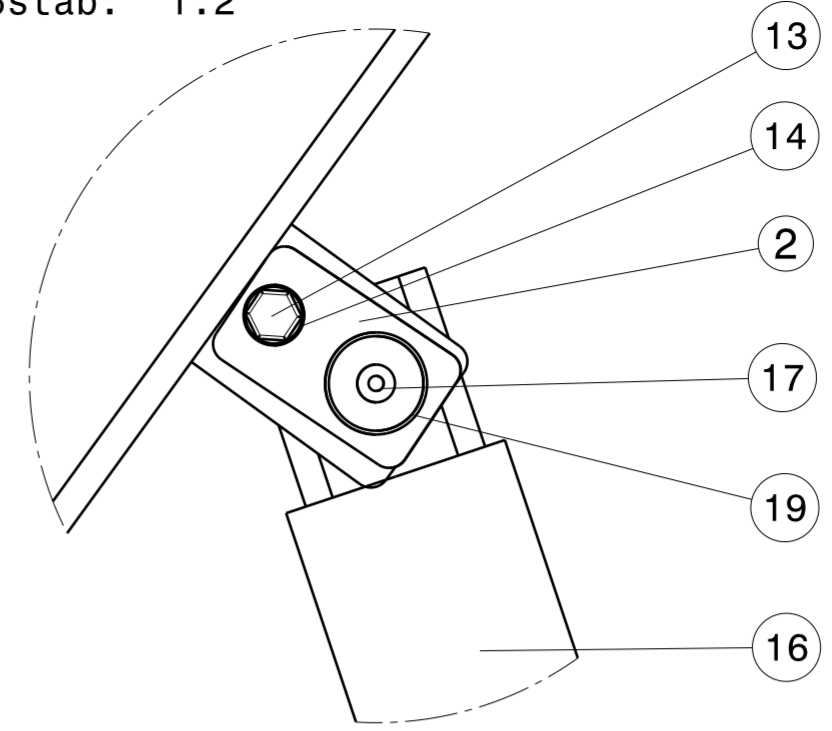

Detail B
Maßstab: 1:2

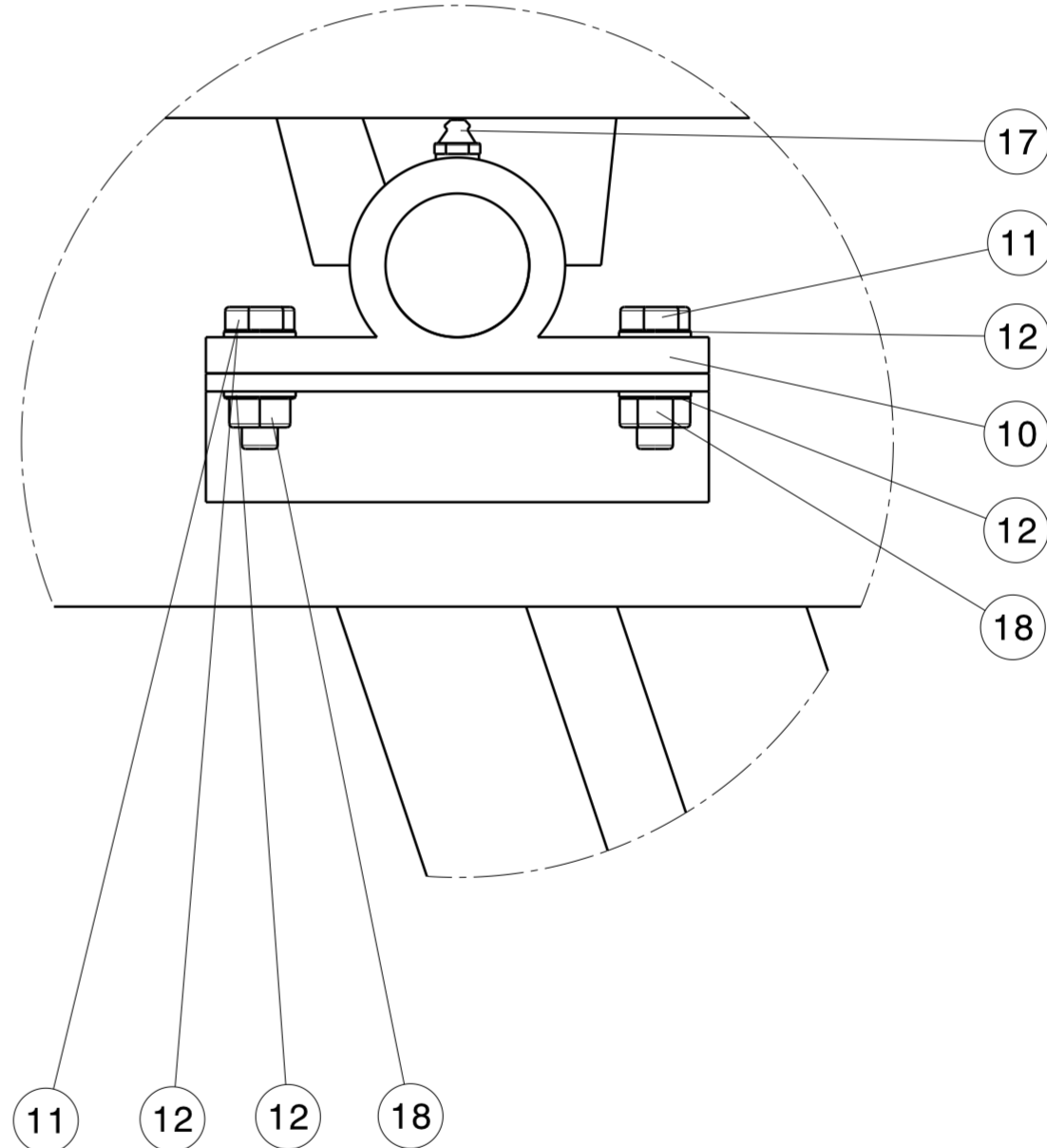

Detail C
Maßstab: 1:2

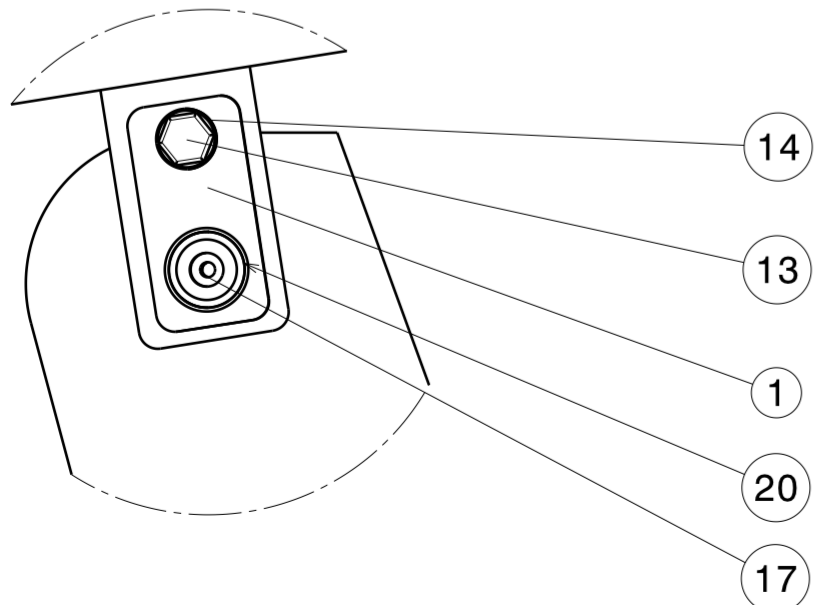

Bolzen mit Schmierfett oder ähnlichem einsetzen
Anziehdrehmomente nach DIN 13-13 für Schrauben M8-25 Nm, M10-48 Nm

Tolerierung ISO 8015		Allgemein-toleranz ISO 2768- mK	Werkstück-kanten DIN ISO 13715	Maßstab 1:5 (1:2)	Masse - kg
	Datum	Name	Zusammenbauzeichnung		
Bearb.	15.06.17	M. Kranz			
Gepr.					
Norm					
CATIA V5			PiccoI_1000-01 (2)		Blatt
 WHZ University of Applied Sciences			Bl.		
Zust.	Änderung	Datum	Name	Dateiname	